



PANDO



1.660,00 €

SKU: DPA128RN00C7010

Brand: RivaViva

Boiserie Riva srl
00199 Roma - Via Nemorense 37/c
Tel. +39068845 253- P.IVA e C.F 05 229581003
info@riva.it - <https://www.riva.it>

Showroom
20159 Milano - Via L. Porro Lambertenghi 18
Tel. +39026883199
milano@riva.it

Showroom
00199 Roma - Via Nemorense 37/c
Tel. +39068845 253
roma@riva.it



GALLERY IMAGES



Pando is an **eco-friendly sofa bed** with a **soft and enveloping design**. A first, simple gesture transforms it into an **elegant dormeuse** with sinuous lines. A second, in a **comfortable bed**, with its cotton and latex futon mattress. RivaViva uses only **solid wood** from **controlled cultivation**, whose processing and finishing steps are marked by total respect for the environment, and chooses only **100% natural fabrics and fillings**. The 12 cm high futon mattress is made of 90-95% cotton and 5-10% foam. The outer cover is 80% cotton + 20% polyester.

The **RivaViva** brand offers a line of **natural and environmentally sustainable furniture**. Each product is made of **solid wood with a beeswax finish**, using only **non-toxic** and environmentally friendly raw **materials**. A **passion for design** and extreme attention to the **use of wood and natural waxes** are the core values of the RivaViva brand.

Boiserie Riva srl

00199 Roma - Via Nemorense 37/c
Tel. +39068845 253- P.IVA e C.F 05 229581003
info@riva.it - <https://www.riva.it>

Showroom

20159 Milano - Via L. Porro Lambertenghi 18
Tel. +39026883199
milano@riva.it

Showroom

00199 Roma - Via Nemorense 37/c
Tel. +39068845 253
roma@riva.it



ADDITIONAL INFORMATION

| | |
|-----------------------------|------------------------|
| Dimensioni divano | 215x95x40/85 |
| Dimensioni materasso | 75x200 |
| Essenza | Oak |
| Colore futon | Linen 914, Natural 701 |

Boiserie Riva srl
00199 Roma - Via Nimorense 37/c
Tel. +39068845 253- P.IVA e C.F 05 229581003
info@riva.it - <https://www.riva.it>

Showroom
20159 Milano - Via L. Porro Lambertenghi 18
Tel. +39026883199
milano@riva.it

Showroom
00199 Roma - Via Nimorense 37/c
Tel. +39068845 253
roma@riva.it



THE PRIMARY PRINCIPLE

Boiserie Riva S.r.l pays the utmost attention to people's well-being and safety, offering furnishings in perfect balance between a culture of personal health and an eco-sustainable philosophy.

HEALTH AND SAFETY MORE THAN NATURAL Riva controls the total of the production process: planning and design, selection and purchase of timbers, craftsmanship and finishing. Every detail is entrusted to expert hands treasure experience dating back to the 1920s, handed down and updated, divorced from traditional industrial processes.

RIVA: HOW IT OPERATES

- Boiserie Riva S.r.l uses only solid wood from controlled cultivation, whose processing and finishing stages are marked by total respect for the environment, and chooses only 100% natural fabrics and padding.
- Boiserie Riva S.r.l adheres to Federmobili's Code of Ethics.
- Boiserie Riva S.r.l pays special attention to Corporate Social Responsibility.

RIVA: AWARDS

- Boiserie Riva S.r.l joins the Vero Legno Consortium, a trademark registered in all countries of the European Union, guaranteeing and authenticity of wood products, protecting the consumer.
- Boiserie Riva S.r.l in 2010, thanks to its commitment to research and production of eco-sustainable furniture, became Legambiente Point. Each month Legambiente sponsors a RivaViva product.
- Cristina Riva joins Federmobili's Leader Group as a national adviser.
- Boiserie Riva S.r.l is a partner of the Best Up Circuit, for the promotion of sustainable living.
- Boiserie Riva S.r.l in June 2017 received the Interior Architecture Award as part of the Rome Architecture Award of the Order of Architects of Lazio with the house "Doubling Home."
- Boiserie Riva S.r.l complies with the requirements of ISO 9001:2015, ISO 14001:2015, ISO 45001:2018



Boiserie Riva srl
00199 Roma - Via Nemorense 37/c
Tel. +39068845 253- P.IVA e C.F 05 229581003
info@riva.it - <https://www.riva.it>

Showroom
20159 Milano - Via L. Porro Lambertenghi 18
Tel. +39026883199
milano@riva.it

Showroom
00199 Roma - Via Nemorense 37/c
Tel. +39068845 253
roma@riva.it

Scheda di montaggio LettoDivano Pando

UTENSILI NECESSARI PER IL MONTAGGIO:

Martello di gomma
Cacciavite a croce grande
Chiave a brugola esagonale n.4

ELEMENTI:

1 : n.1 Schienale
2 : n.1 Fascia anteriore
3 : n.3 Braccioli
4 : n.2 Traverse rettangolari
5 : n.2 Traverse trapezoidali
6 : n.6 Doghe

FERRAMENTA:

A : n.8 Perno tirante
B : n.8 Barilotto per perno tirante
C : n.8 Grano per barilotto
D : n.4 Perno metallo
E : n.16 Spine di legno
F : n.4 Piastre in metallo in metallo ad "S"
G : n.8 Viti a brugola autofilettanti per legno

ISTRUZIONI PER IL MONTAGGIO:

Fase 1: Inserire le spine di legno (E) ed i barilotti per i perni tiranti (B) nei fori delle traverse rettangolari (4) e traverse trapezoidali (5)

Fase 2: Avvitare i Perni tiranti (A) nelle boccole filettate dello schienale (1) e fascia anteriore (2)

Fase 3: Inserire con un martello di gomma i perni in metallo (D) nei fori laterali dei braccioli (3)

Boiserie Riva srl

00199 Roma - Via Nemorense 37/c
Tel. +39068845 253- P.IVA e C.F 05 229581003
info@riva.it - <https://www.riva.it>

Showroom

20159 Milano - Via L. Porro Lambertenghi 18
Tel. +39026883199
milano@riva.it

Showroom

00199 Roma - Via Nemorense 37/c
Tel. +39068845 253
roma@riva.it

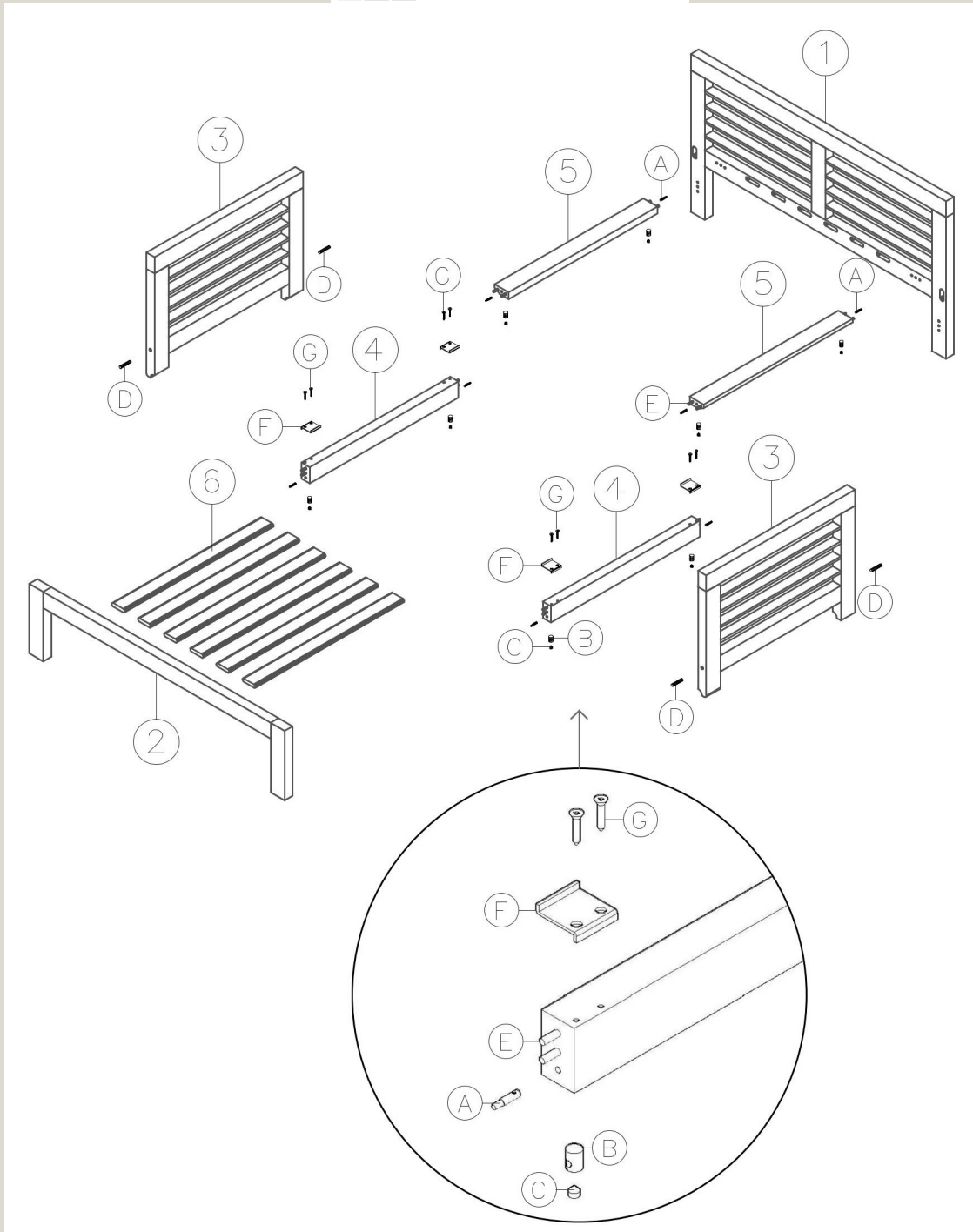

Fase 4: Avvitare le piastre di fermo in metallo ad "S"(F) tramite apposite viti a brugola autofilettanti per legno (G) nei fori delle traverse rettangolari (4) verificare verso come disegno

Boiserie Riva srl
00199 Roma - Via Nemorense 37/c
Tel. +39068845 253- P.IVA e C.F 05 229581003
info@riva.it - <https://www.riva.it>

Showroom
20159 Milano - Via L. Porro Lambertenghi 18
Tel. +39026883199
milano@riva.it

Showroom
00199 Roma - Via Nemorense 37/c
Tel. +39068845 253
roma@riva.it

Fase 5: Appoggiare lo schienale (1) sdraiato su una superficie piana ed inserire le traverse rettangolari (4) e traverse trapezoidali (5) sulle spine di legno (E) facendo corrispondere all'interno dei barilotti (B) il foro dei perni tiranti (A) inserire i grani (C) nei barilotti (B) delle traverse (4) e (5) ed avvitare con un cacciavite fino a serraggio completo

Fase 6: Inserire le doghe (6)

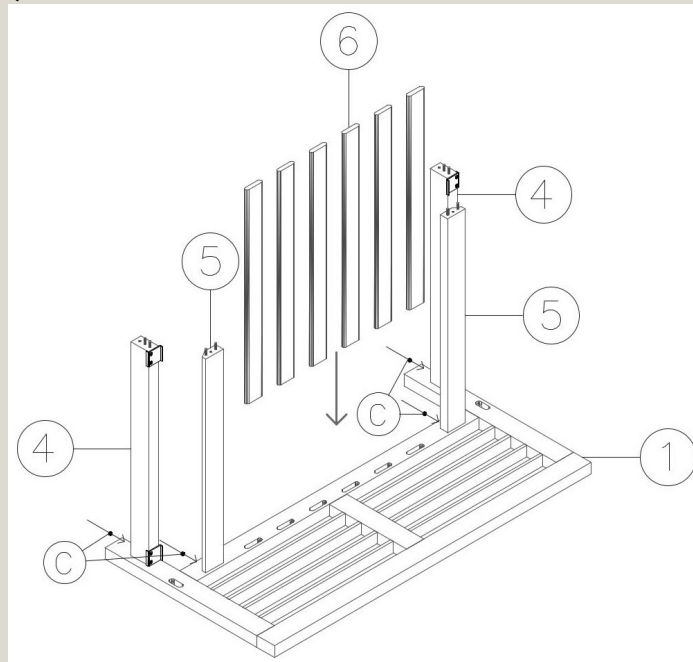

Fase 7: Inserire i braccioli (3) facendo corrispondere i perni in metallo (D) negli incavi ovali dello schienale (1)

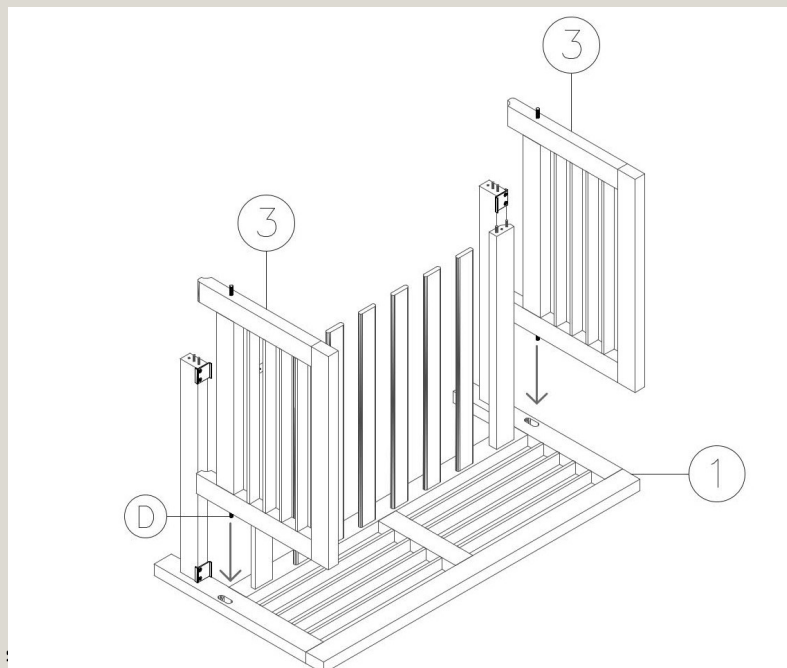

Boiserie Riva :

00199 Roma - Via Nemorense 37/c
Tel. +39068845 253- P.IVA e C.F 05 229581003
info@riva.it - <https://www.riva.it>

20159 Milano - Via E. Forno Lambertenghi 10
Tel. +39026883199
milano@riva.it

Showroom

00199 Roma - Via Nemorense 37/c
Tel. +39068845 253
roma@riva.it

Fase 8: Inserire la fascia anteriore (2) facendo corrispondere:

1. i perni in metallo (D) dei braccioli negli incavi ovali della fascia anteriore (2)
2. le spine di legno e perni tiranti (A) nelle traverse rettangolari (4) e traverse trapezoidali (5)
3. le doghe (6) negli appositi incavi della fascia anteriore
- 4.

Fase 9: spingere la fascia anteriore (2) verso lo schienale (1) a chiudere la struttura aiutandosi con un martello di gomma

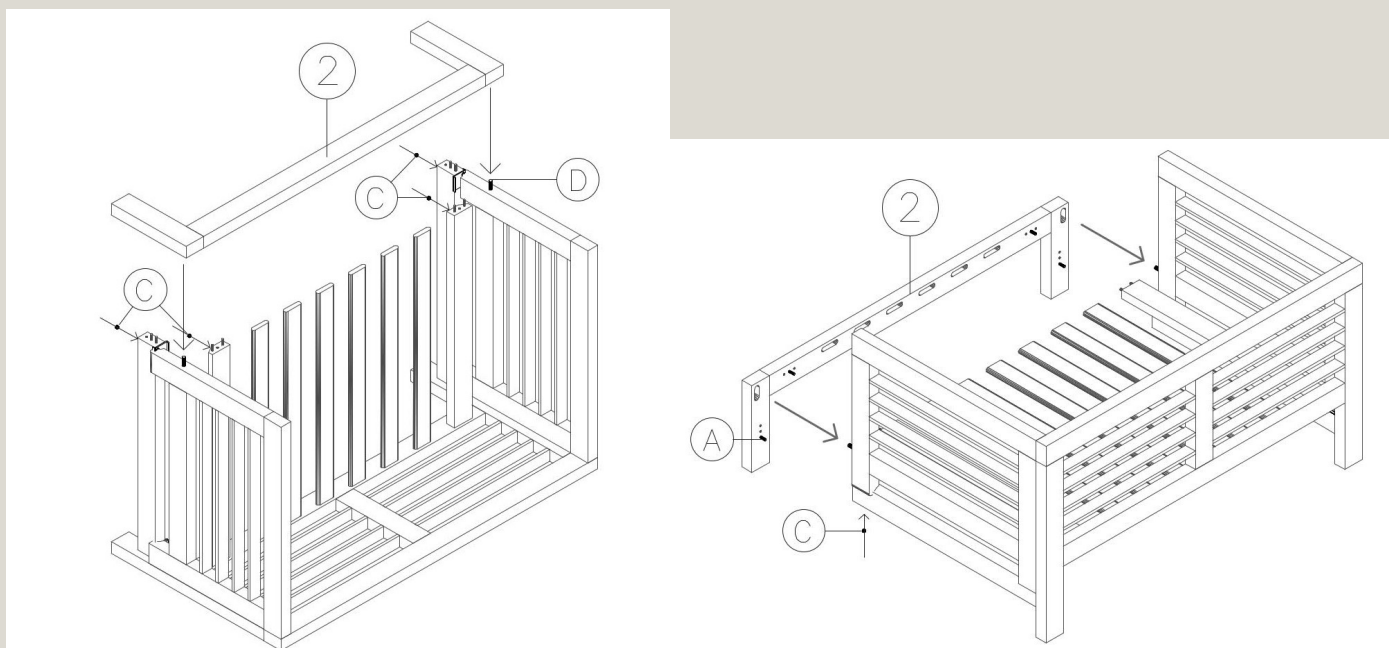

Fase 10: inserire i grani (C) nei barilotti (B) delle traverse (4) e (5) ed avvitare con un cacciavite fino al serraggio completo.